

Vendor Performance Requirements Manual

Updated: February 5, 2024



Table of Contents

Welcome to Sally Beauty Holdings.....	4
Electronic Data Interchange (EDI) Requirements.....	5
SBH Transaction Sets	6
EDI New Vendor Onboarding	7
Electronic Purchase Order (850)	8
Purchase Order Acknowledgment (855).....	9
Purchase Order Change (860)	10
Purchase Order Change Acknowledgment (865).....	11
Advanced Ship Notice / ASN (856).....	12
Electronic Invoice (810)	13
Warehouse Efficiencies and Accuracy	14
Inbound Appointment Scheduling	14
Overall Pallet Requirements	15
Pallet Label Requirements.....	16
Packing Slip Requirements and Placement	17
Packing Slip Contents Requirements	18
Carton Label Requirements.....	19
Carton Label GS1-128.....	20
GS-128 Label Specifications	21
Other Packaging Requirements.....	23
Commitment to Sustainability	24
Regulatory Carton and Product Markings	25
Purchase Order, Accuracy and Floor Ready.....	26
Transportation Requirements.....	27
Applicability	27
Updating Fulfillment & Transit Times	27
Collect Shipments to SBH	28
Vendor Shipment Error Notification	29
Vendor Scorecard.....	30
Scorecard Formulas	31
Warehouse Load Evaluation Metrics	33
At a Glance	34

Contact Information and Important Links34

Distribution Center Listing.....35

Requirements Checklist Table36

2023 Changes37

 Immediate or Cancel Policy37

 Delivery Windows38

 EDI Mapping Changes40

 EDI Timeline 2023-202443

 Integration of Vendor ASN to SBH Warehouse Management Systems.....44

 Canada PO Migration45

Change Control.....46

Welcome to Sally Beauty Holdings

Whether you are a new or existing vendor with Sally Beauty Holdings, Inc. (SBH) which includes the following banners, **Sally Beauty Supply, Beauty Systems Group and Happy Beauty Co.**, the following set of requirements must be followed to engage in a business relationship with SBH. The adherence to these requirements will enable our Vendor Performance Team, Distribution Centers, Buying Teams and Accounts Payable to receive, stock and process your shipments for payment and serve our customers effectively, accurately, and quickly.

The requirements in the following document will cover important information on:

- How to electronically communicate with SBH via EDI
- Prepare shipping documents such as packing slips
- Carton, label, and pallet requirements
- Purchase order accuracy and shipping window expectations
- Appointment requirements
- Transportation
- Regulatory carton and product markings

All references in the document are to SBH and will apply to all banners as listed above.

For more information, please reach out to the Vendor Performance Team vendorperformance@sallybeauty.com. You can also find this Manual and our Supplier Code of Conduct, as each may be updated from time to time, at <https://www.sallybeauty.com/vendor-compliance-guide.html>.

This Manual replaces "Sally Beauty Holdings, Inc. Vendor Guide For Merchandise Vendors" April 8, 2019. Any failure of SBH to enforce the requirements contained herein does not constitute a waiver or an exemption from the requirement. If a vendor fails to meet such requirements, we reserve our ability to take decisive corrective action, up to and including cancellation of contracts and termination of our relationship.

Electronic Data Interchange (EDI) Requirements

EDI will enable SBH to electronically exchange business information in efforts to facilitate speed and accuracy. To effectively exchange data, both SBH and our vendors must utilize the same formatting for all fields (data maps), which will require testing and validation before a vendor can be considered an active EDI trading partner.

Benefits

- Improved operational efficiency and accuracy
- Enhanced visibility to data
- Faster payment to vendors

Requirements

- SBH requires all vendors to be 100% EDI compliant and successfully exchanging all required documents
- SPS Commerce is SBH's partner for EDI testing, validation, and VAN services
- Although SPS is the dedicated VAN for SBH, you may choose to use any EDI provider for your EDI needs
- The following documents must be tested with SPS Commerce and pass to become EDI compliant and active with SBH:
 - Purchase Order (850)
 - Purchase Order Acknowledgement (855)
 - Purchase Order Change (860)
 - Purchase Order Change Acknowledgement (865)
 - Advanced Ship Notice (856)
 - Invoice (810)

SBH Transaction Sets

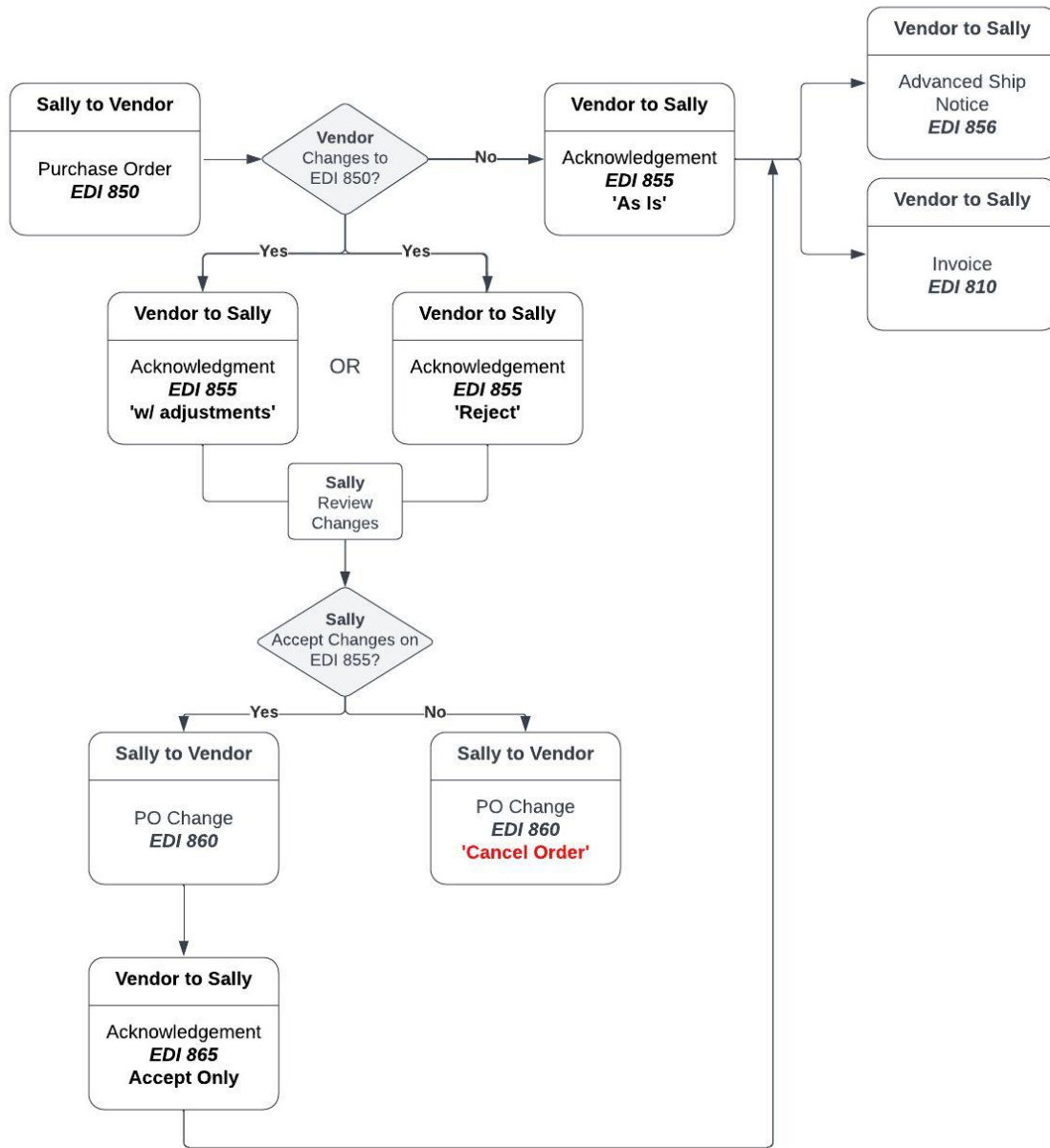

EDI New Vendor Onboarding

SPS Commerce is SBH's partner for EDI testing, validation and VAN services. If you are a new vendor with SBH, the following process will occur for your EDI activation.

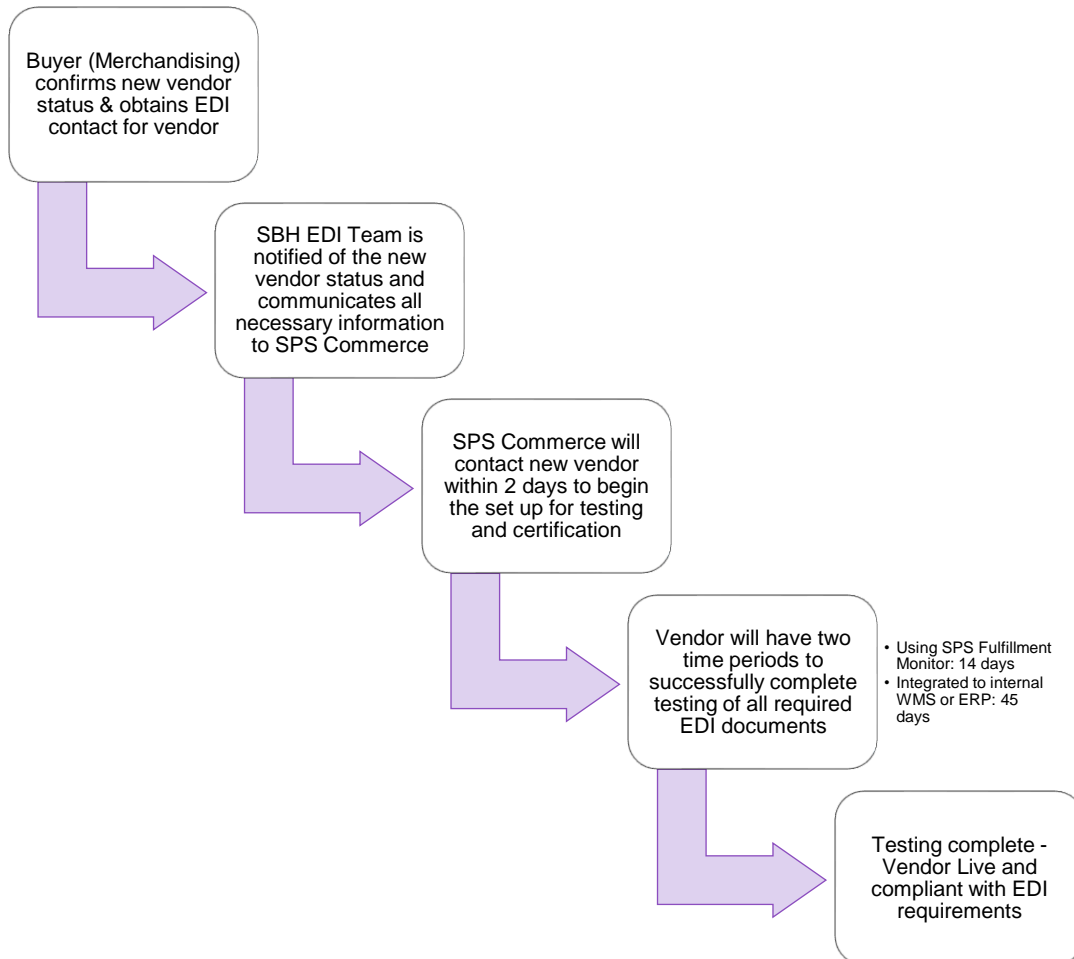

1

Important Information

- Vendor must provide an EDI contact (internal or third party) to Merchandising contact to prevent delays in activation
- SPS will contact new vendor once 'Vendor Onboarding' process is complete
- Please visit our website "Current EDI Specifications" to become familiar with our transaction sets and mapping requirements: <https://www.sallybeauty.com/vendor-compliance-guide.html>

Electronic Purchase Order (850)

This X12 Transaction Set contains the format and establishes the data contents of the Purchase Order Transaction Set (850) for use within the context of EDI environment. This transaction set should be used to convey items, quantity, costs, ship to location, allowances, and delivery window.

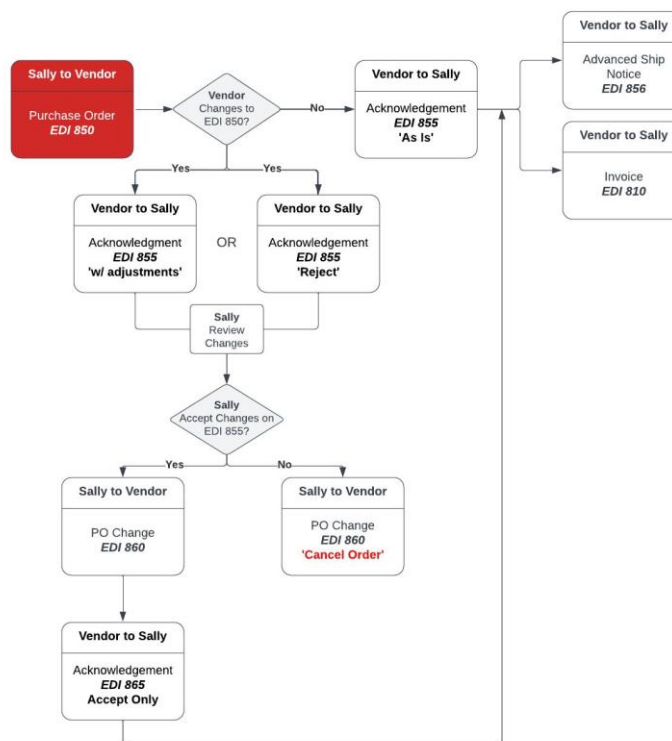

Requirements

- Purchase Order will only contain one designated Distribution Center/Ship to Location
- Only one shipment per purchase order
- Any changes to the Purchase Order must be communicated through the EDI 855 document within 48 hours of purchase order receipt. SBH will not honor changes made via email.²

Purchase Order Acknowledgment (855)

This X12 Transaction Set contains the format and establishes the data contents of the Purchase Order Acknowledgment Transaction Set (855) for use within the context of EDI environment. SBH requires this transaction set to be used as an acknowledgment of the purchase order and to notify SBH if there are any adjustments to the purchase order items, quantities, costs, and allowances.

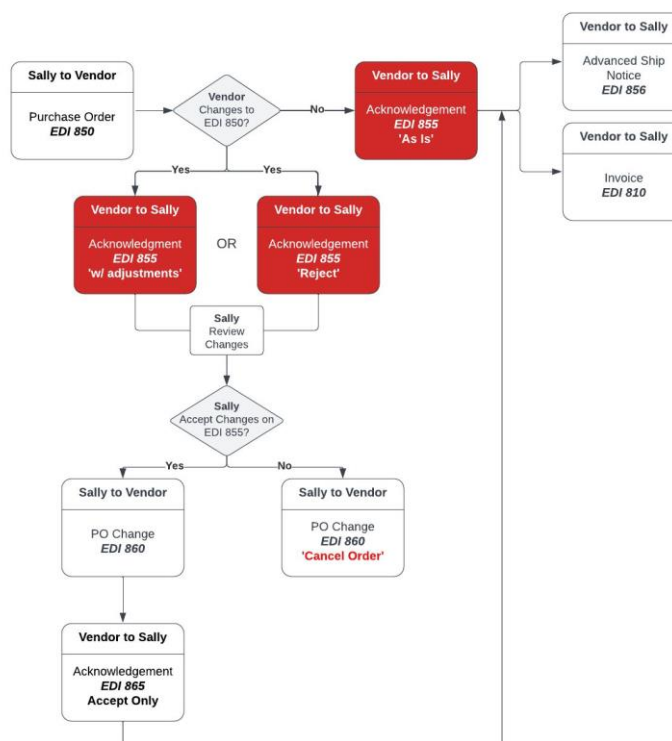

Requirements

- **Must be acknowledged within 48 hours of purchase order receipt**
- Verify all details are correct
- Vendor can take the following actions on the EDI 855
 - Accept “as-is” or reject including line-level information
 - The following adjustments may be made to all Purchase Orders: items, quantities, costs and allowances
 - Please see the SBH [Immediate or Cancel](#) policy to understand date adjustments available by PO Type ³
- This document should not be used as a generic acceptance of the EDI 850 transaction
 - If no EDI 855 is received, SBH will consider all information transmitted on the EDI 850 as a binding agreement with the Vendor
 - Cut reports sent via email may not be used in place of the 855

Purchase Order Change (860)

This X12 Transaction Set establishes the data contents of the Purchase Order Change Request. This will be a SBH Replenishment Planner-initiated transaction set (860). This transaction will be used: (1) by a Replenishment Planner to request a change to a previously submitted purchase order or (2) by a Replenishment Planner to confirm acceptance of a Purchase Order Acknowledgement (855) initiated by the Vendor.

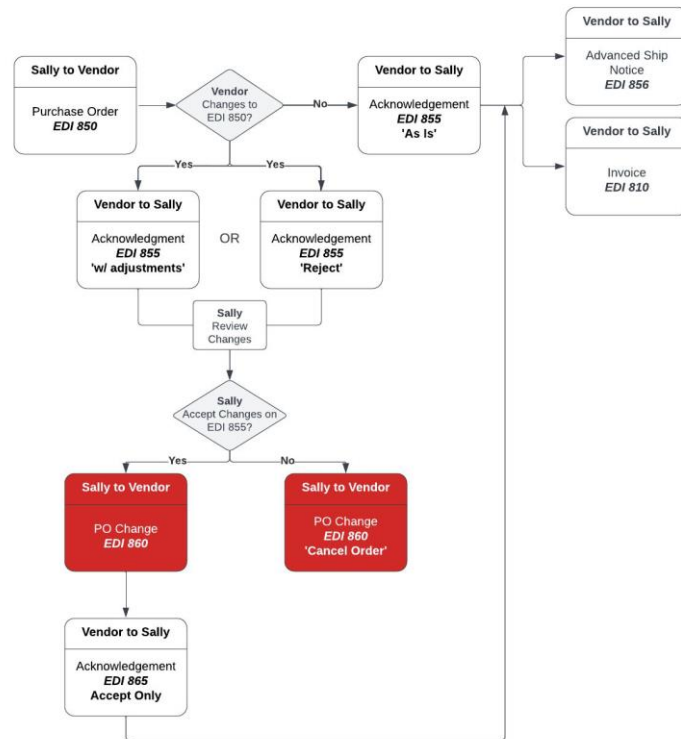

Requirements

- SBH will transmit the EDI 860 if necessary, based on the details of the inbound EDI 855
- SBH will transmit the EDI 860 within 48 hours of receiving the EDI 855 from the Vendor
- If SBH does not agree to the requested changes for quantity or date, the Replenishment Planner will communicate to the Vendor to align on a mutually agreeable fulfillment solution within the 48 hour window

Purchase Order Change Acknowledgment (865)

This X12 Transaction Set establishes the data contents of the Purchase Order Change Acknowledgment. This will be a vendor-initiated transaction set (865). This transaction will be used by the vendor to convey the acceptance or rejection of the changes communicated on the EDI 860 (Purchase Order Change).

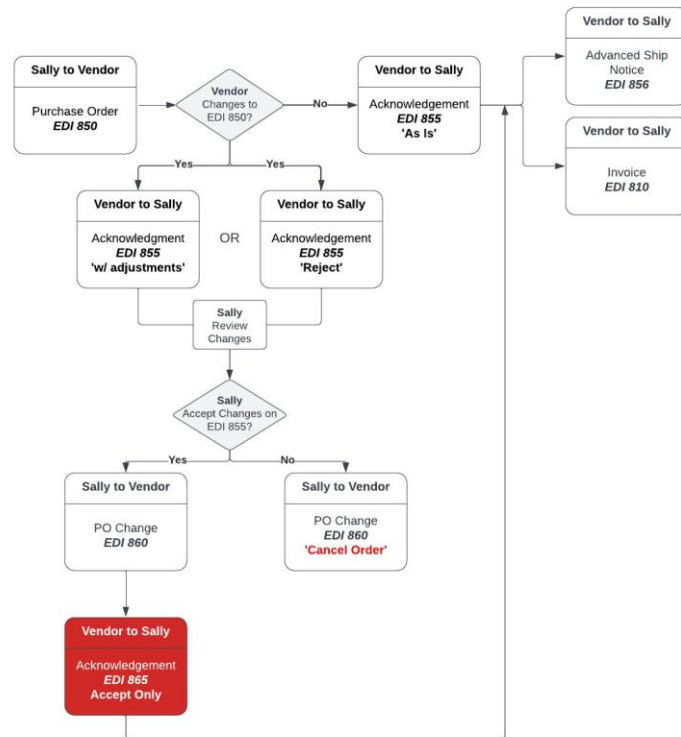

Requirements

- Vendor will transmit the EDI 865 to convey the acceptance of an EDI 860, if one was transmitted to the vendor
- Vendor will transmit the EDI 865 within 48 hours of receiving the EDI 860 from SBH
- This should not be used to communicate changes during the pick process. Any changes to final quantities should be present on the Vendor Advance Ship Notice.⁴

Advanced Ship Notice / ASN (856)

This X12 Transaction Set establishes the data contents of the Ship Notice/Manifest Transaction Set (856). The transaction should be used to list the contents of a shipment as well as additional information relating to the shipment, such as order information, product description, quantities, and carrier information. The EDI 856 enables the sender to specify the contents and configuration of a shipment at the carton level.

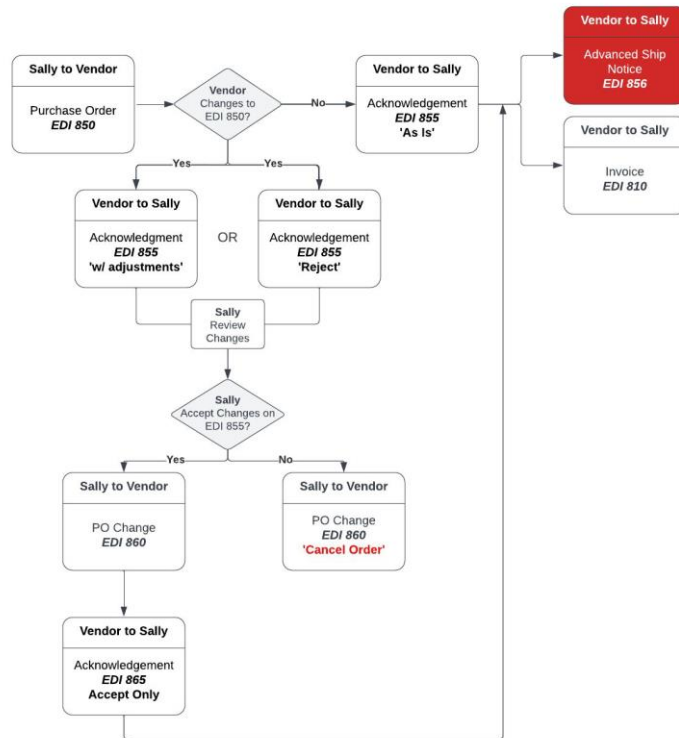

Requirements

- ASN must be received by SBH before a delivery appointment can be made
- **Consolidated ASNs not allowed; only one purchase order per ASN**
- ASN must have a unique BOL number. Do not re-use the same BOL number or put multiple PO numbers in a string into the BOL.
- ASN must contain accurate information corresponding to the purchase order and inbound shipment to SBH

Electronic Invoice (810)

This X12 Transaction Set contains the format and establishes the data contents of the Invoice Transaction Set (810) for use within the context of the EDI environment. The transaction set will be used for the billing for goods shipped against the purchase order and the Advance Ship Notice.

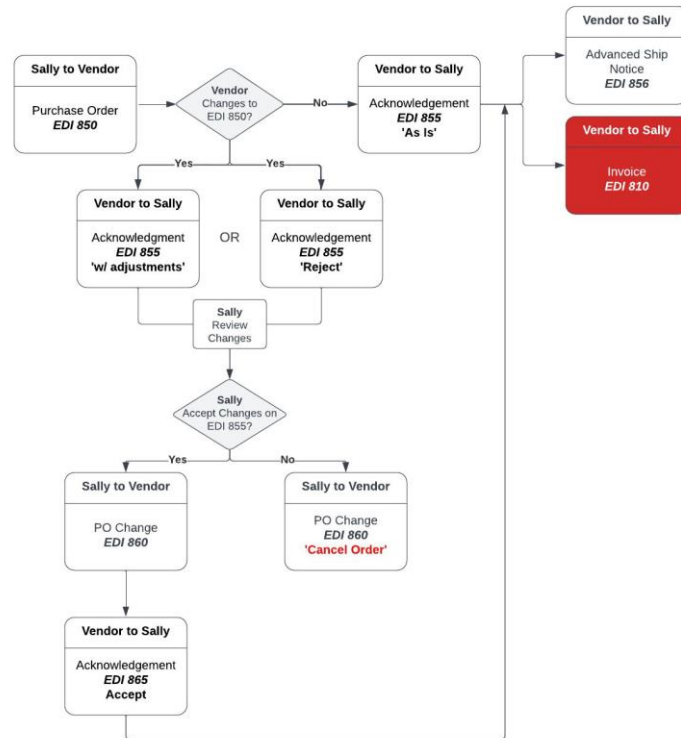

Requirements

- An invoice can only contain one purchase order
- EDI 810 should contain accurate information as to what was shipped against the purchase order to include: items, quantity, costs and allowances.
- All data elements on the invoice must match the most current purchase order along with the ASN, as to not delay payment

Warehouse Efficiencies and Accuracy

Inbound Appointment Scheduling

A vendor ASN must be received by SBH before an appointment can be scheduled. Effective Fall 2022, SBH Supply Chain Distribution Centers have been referencing the ASN number and quantities prior to receipt. The ASN will be fully integrated into the Distribution Warehouse Management Systems for additional accuracy. The ASN will be the source record against which all receiving activity takes place.⁵

SBH reserves the right to decline any appointment request where an ASN is not present.

Requirements

- SBH will conduct an ASN to purchase order validation prior to appointment scheduling
- Appointment request must include all purchase orders that are being delivered, carton count by purchase order and total pallet count in the delivery
- Shipment must arrive on time of scheduled appointment
 - Shipments that arrive later than 60 minutes from scheduled appointment may be rescheduled or asked to wait for dock availability
 - SBH is not responsible for any fees associated with idle or wait time related to an appointment that is late and asked to wait for dock availability
 - SBH will monitor carrier performance on 'on-time' deliveries and accuracy of delivery details
- Shipment must be delivered within the delivery window as stated on the purchase order
- Any shipments delivered without an appointment or outside the delivery window may be turned away at the dock door
- Shipment must be delivered to the correct distribution center location on the purchase order
- SBH requires all LTL and FTL shipments to have appointments for delivery at the designated Distribution Center indicated on the purchase order

Overall Pallet Requirements

Pallet requirements are critical to the safety and efficiency of the inbound receiving process at the SBH Distribution Centers.

Requirements

- Pallets must be in acceptable condition; only wood pallets are permitted
- Pallet must maintain structural integrity to move within the supply chain
- Pallet must be stacked 55" or lower in height and with a standard dimension of 48" X 40"
- Cartons must be secured on the pallet with no overhang
- Keep cases of the same SKU and purchase order on the same pallet and truck unless quantity requires splitting
- Only a single distribution center per pallet

Secured Pallet, no overhang

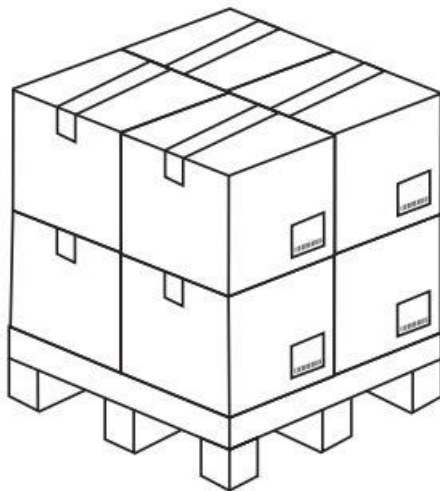

Pallet not secure, cartons not aligned, overhang

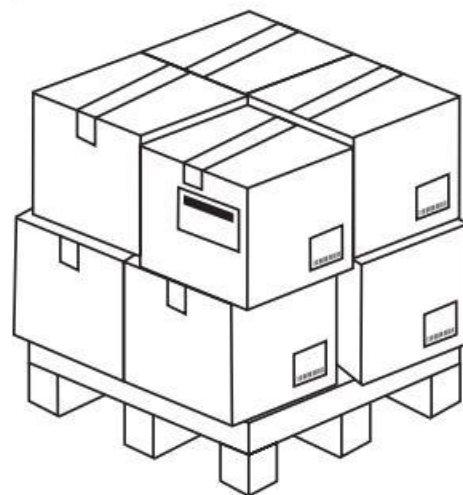

Pallet Label Requirements

Pallet label requirements are important to the inbound receiving process and will aid the Distribution Center to quickly identify and receive shipments.

Requirements

- Where controlled by the Vendor, label must be affixed to the upper right corner of the pallet, positioned on the side facing the door of the trailer⁶
- Pallet label should include the following elements:
 - a. Purchase order
 - b. Distribution center location
 - c. SBH SKU contained on pallet
 - d. UPC # contained on pallet
 - e. Total carton count by SKU (do not include next to UPC)
 - f. Total pallet carton count
- If there are multiple SKUs on one pallet, the pallet must be clearly labeled “Mixed SKU”

Sample Pallet Label

PO Number (a)	123456789
Distribution Center (b)	Columbus, OH
MIXED SKU	Cartons
SKU # 12345 (c)	6 (e)
UPC # 1234567890123 (d)	
SKU # 9123	6
UPC # 3210987654321	
SKU # 87654	6
UPC # 2345678901234	
SKU # 67859	6
UPC # 4321098765432	
Total # SKUs/ UPCs on pallet	4
Total cartons on pallet	24 (f)

Label placement and positioning

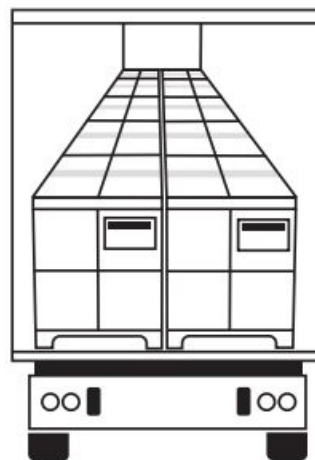

Packing Slip Requirements and Placement

SBH requires all shipments to contain a packing slip, indicating the contents of either the shipment or the single carton (small parcel) deliveries.

Requirements

- Packing slip is required for all shipments
- Packing slip must be located/affixed:
 - Small parcel: Packing slip required on each carton – showing only contents of that carton.
 - LTL shipments: Packing slip(s) must be affixed in an exterior sleeve beside pallet label on the last pallet of the loaded shipment facing trailer door. Packing slip contained should only be for cartons on said pallet.
 - FTL shipments: Packing slip(s) must be affixed in an exterior sleeve beside pallet label on the last pallet loaded on the trailer, facing the door of the trailer⁷

Examples

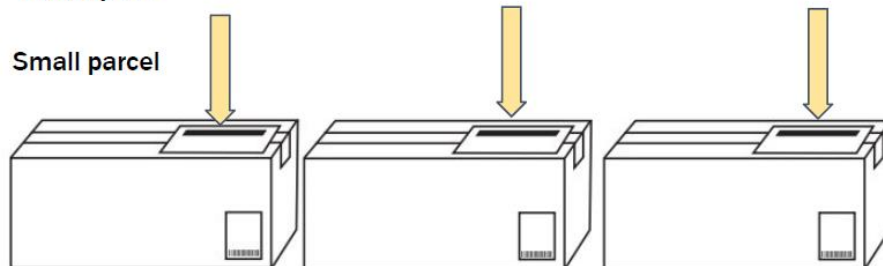

LTL shipments

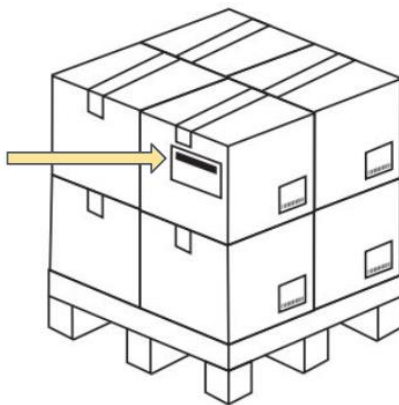

FTL shipments

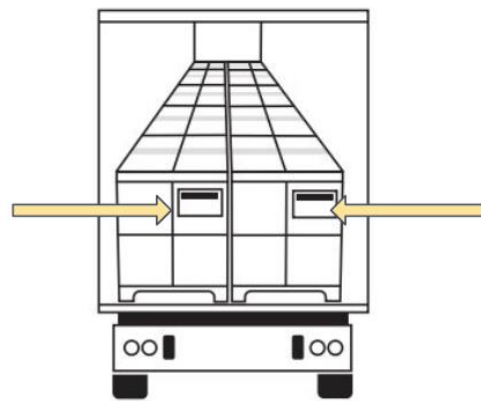

Packing Slip Contents Requirements

SBH requires all shipments to contain a packing slip, indicating the contents of either the shipment or the single carton (small parcel) deliveries.

Requirements

- Packing Slip (example below) must contain:
 - a. Purchase order number
 - b. Delivery location (Warehouse)
 - c. SBH SKU number
 - d. Vendor item number
 - e. Item Description
 - f. Item level UPC#
 - g. Unit quantity (eaches)
 - h. Total quantity in carton
 - i. Total carton count of shipment

[Your Company Name] [Street Address], [City, ST ZIP Code] [Phone] [Fax] [e-mail]				DATE: PACKING SLIP #		
BILL TO [Company Name] [Street Address] [City, ST ZIP Code]			SHIP TO (b) Distribution Center # [Street Address] [City, ST ZIP Code]			
(a) PURCHASE ORDER	(h) TOTAL CARTON COUNT	WEIGHT	VENDOR #	DELIVERY DATE	DUE DATE	
(c) SBH SKU NUMBER	(d) VENDOR ITEM NUMBER	(e) ITEM LEVEL UPC #	(f) ITEM DESCRIPTION	COLOR	UNIT PRICE	(g) UNIT QTY (EACHES)
(g) TOTAL						

Carton Label Requirements

SBH requires all cartons to have a permanently attached carton label to aid the Distribution Center in the receiving process. The purpose of the GS1-128 is to connect the physical units of a Vendor's shipment with its electronic information presented on the Advance Ship Notice (856).⁸

Requirements

- All cartons must be labeled with a scannable GS1-128 label, following the GS1 technical formatting standards and the SBH-specific label data fields
- The Serialized Shipping Container Number must be present on the associated ASN
- It is the responsibility of the Vendor to confirm GS1-128 label matches the ASN data
- Cartons more than 6" tall should have the label permanently affixed in a vertical orientation to the bottom right-hand corner of the carton, on the longest side
- Cartons less than 6" tall should have the carton label placed as stated above, with the excess of the top portion of the label folded over the top of the carton
- Do not cover taped seams with labels or place label on top of the carton
- Please note that a packing slip does not count as a carton label
- Label size should be 4" x 6", at least ANSI "C" grade

Examples



Carton Label GS1-128

Requirements

- a. Purchase order number
- b. Delivery location (warehouse)
- c. SBH SKU number
- d. Vendor item number
- e. Item level UPC# & Scannable Barcode
- f. Vendor description - from 850 & 856
- g. Case quantity
- h. GS1-128 barcode
- i. Carton count sequence number (1 of xxxx)

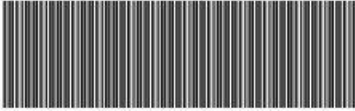
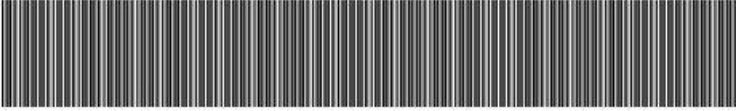
Ship From: Ship From Name Address 1 Address 2 City, State Postal Code Country	Ship To: Ship To Name (b) Address 1 Address 2 City, State Postal Code Country
(420) Ship To Postal Code  (420) 85263	Carrier: B/L: Pro: Number of Cartons: (i) 1 of XXXX
PO #: (a) SBH SKU #: (c) Vendor Item #: (d) Item UPC & Scannable Barcode (e) Item Desc: (f) Carton Qty: 1 (g)	
Serialized Shipping Container Number (h)  (00) 0 125385 012345678 9	

GS-128 Label Specifications

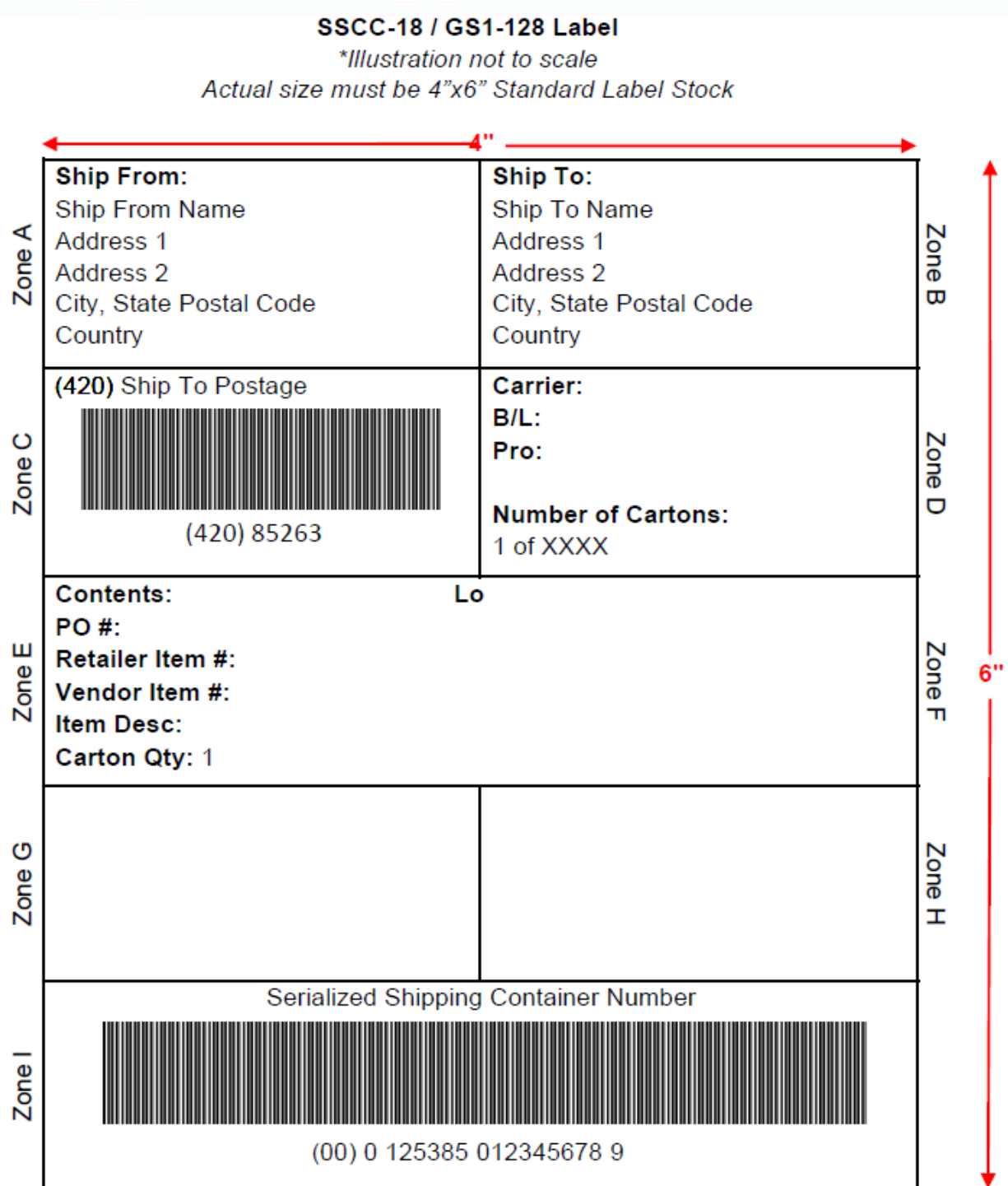

Continued on next page

The label format that is known as the GS1 US Common Label for use in North America. The example shows all zones in accordance with GS1 US Common Label (GS1-128).

Note: Minimum label requirements are highlighted in red

Zone	Description	Font	Required Information
A	Ship From Information	8-10 pt	Ship From Name Street Address City, State, Postal Code, Country
B	Ship To Information	12-14 pt	Ship To Name (including the retailer location number) Street Address City, State, Postal Code, Country
C	Ship To Postal Code # and Bar Code		Ship To Postal Code # Bar Code with human readable text
D	Carrier Information	10-16 pt	Carrier Name or SCAC code B/L (this would be the Bill of Lading #) Pro (this would be one of Carrier Pro # or Parcel Tracking #) Carton Count per Shipment
E	Customer/Retailer Information	10-18 pt	Purchase Order # Contents (This would be the retailer's item #, the vendor's item #, and the item's description; if more than 2 state 'MIXED') Quantity per Carton or Pallet Lot Number (when Applicable)
F			
G	Location Bar Code		
H	Location Number		
I	Serialized Shipping Container Code - SSCC		SSCC Bar Code with human readable text

Other Packaging Requirements

SBH requires cartons being shipped be of good quality, specific size, weight and with appropriate packing material to ensure safety within the Distribution Centers and to limit damages to merchandise being shipped.

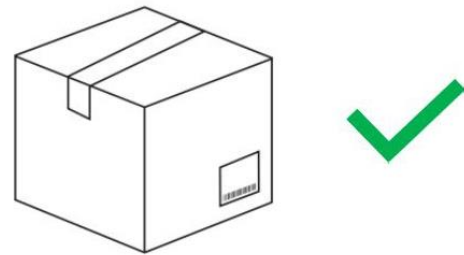

SBH recognizes that the physical dimensions of some of our assortment results in casepacks that fall below minimum dimensions or are delivered in airpaks.

Vendor is permitted to package smaller casepacks or loose goods ordered in the casepack minimum into a larger container carton for safety in handling. In

addition, some goods may be above the dimension or weight minimum. SBH uses these dimensions as guardrails for efficiency, safety and ergonomics in our warehouse environment.

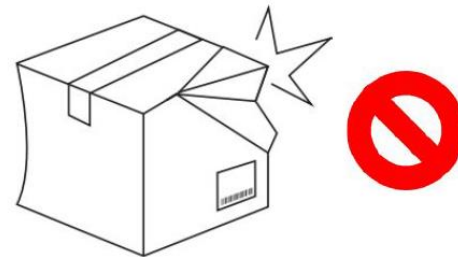

Requirements

- Cartons must be sealed properly and maintain structural integrity to move within the supply chain
- Carton dimensions & weight requirements: ⁹

	Minimum	Maximum
Length	9"L x 7"W x 3"H 18 x 23 x 8 cm	25"L x 22"W x 23"H 64 x 56 x 58 cm
Mass	2 lbs 1 kg	50 lbs 22 kg

Commitment to Sustainability

Requirements

- Cartons must have inner voids filled with acceptable packing materials (dunnage)
- The use of **sustainable packing materials** is preferred. Packing materials accepted and have sustainability options include: bubble wrap, eco-friendly foam, ranpak, air pillows, eco-friendly molded inserts, and recyclable paper
- The following packing materials are not allowed: styrofoam peanuts, shredded paper, printed newsprint, and confetti



BE PART OF SOMETHING BIGGER.

Take care of each other, our community, and our planet.

Regulatory Carton and Product Markings

SBH follows the DOT and Federal Motor Carrier Safety Administration's requirements on handling and marking cartons containing hazardous materials. Along with the adherence to hazardous materials, SBH also complies with FDA regulations including the assurance that products sold are within the expiry date. SBH's new item and vendor onboarding process contains all required product specifications.

The below requirements are strictly for the shipment of goods to SBH Distribution Centers.

Requirements

- All cartons containing hazardous chemicals must be labeled with the appropriate hazardous markings and/or labels
- Please reference the Federal Motor Carrier Safety Administration's Hazardous Carton Marking Guidelines. They can be found following this link: <https://www.fmcsa.dot.gov/sites/fmcsa.dot.gov/files/2021-06/usdot-chart-16-10-24-2017.pdf>
- SBH requires shelf life for all products to exceed 12 months and all products, with expiration dates, must be received greater than 12 months from expiration
- All cartons loaded on a single pallet should only be from a single lot number, for a single SKU pallet. No mixed lot numbers on a single pallet for the same SKU.

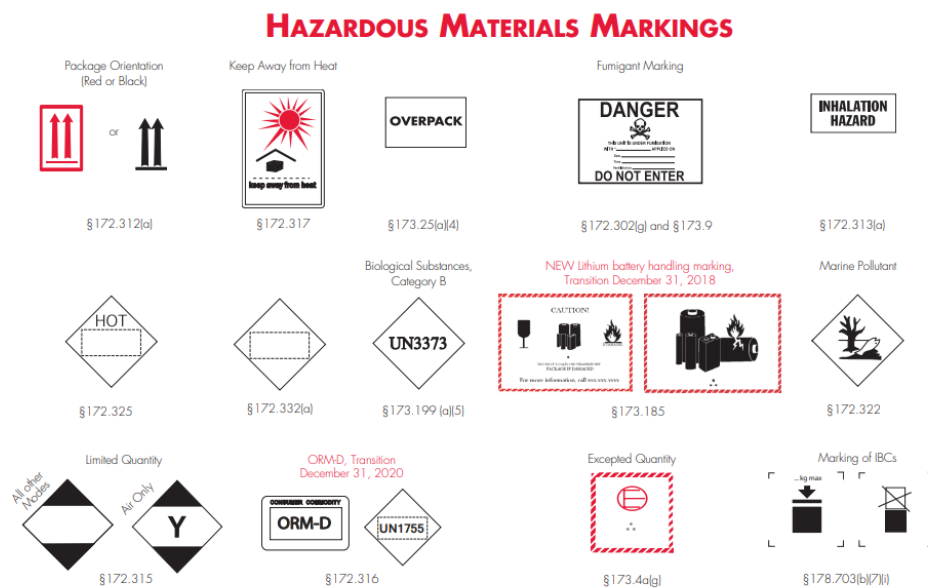

Purchase Order, Accuracy and Floor Ready

Purchase Order Accuracy is critical to the success of products being shipped and sold through SBH. It is a standard expectation that a vendor ship what is ordered and within the expected delivery window. SBH will monitor end to end purchase order accuracy. In addition to the importance of the accuracy, all products shipped must have a scannable UPC either affixed or printed on the sellable item for a product's floor ready requirement.

Requirements

- Purchase order must ship complete and in full
- Must ship within the delivery window as stated on the purchase order EDI 850
- Only ship items and quantities on the final purchase order
- Substitutions are not permitted
- Overages are not permitted
- UPC (GTIN-12) barcode labeling required on all products

Transportation Requirements

Applicability

Please follow the below general shipping instructions when shipping to SBH. These instructions apply to shipments within the continental United States, as well as to Alaska, Hawaii, Puerto Rico, and Mexico.

Requirements

- All shipments require an appointment for delivery
- Only one shipment per purchase order unless order quantity exceeds a full truckload
- Shipments under 15 cartons and 200 lbs. should be sent via a small parcel carrier
- When shipping LTL, the vendor must list the Classification on the BOL. Classification can be found in the [National Freight Classification Manual](#), which is required by the Department of Transportation
- Bill of Lading should contain and list out the number of boxes per pallet
- Vendor must contact TPS Logistics at SPA@TPSlogistics.com for Carrier EDI requirements

Updating Fulfillment & Transit Times

In order to produce accurate Delivery Windows, please click [HERE](#) to provide Fulfillment and Transit number of days to each SBH Distribution Center. These dates will be used to determine [Delivery Window](#) date ranges.

Collect Shipments to SBH

Consignee	Freight Bill
All SBH Vendors	Sally Beauty % TPS Logistics PO Box. 490 Troy, MI 48099

Load Type	Approved Carriers
<p>Parcel Carton > 40 lbs. or any package with its length (longest side of the carton) + girth (2x width) + (2x height) combined exceeding 105" in length or any package with the longest side > 48" wide or any packages with its second longest side > 30"</p>	UPS: 1-800-742-5877
<p>Less Than Truckload (LTL) 200-10,000 lbs. or less than 12 linear feet</p>	XPO Logistics ¹⁰ (800) 755-2728 https://ext-web.ltl-xpo.com/landing
<p>Truckload shipments (TL) Greater than 10,001 lbs. and greater than 12 linear feet</p>	TPS Logistics (248) 731-4725 SBA@tpslogistics.com

Vendor Shipment Error Notification

Effective April 2023, SBH is sending auto-email notifications to alert Vendors of shipping errors: overages, shortages, substitutions, damages, and incorrect delivery location. This system is also used to request Return Authorizations. This new portal is a powerful control mechanism for both Vendor and SBH to track these activities in an organized manner. Purchase Order, SKU-level detail and photos will accompany notifications where applicable.

Emails will come from “SBH Shipment Errors” and require a first-time account setup and authentication upon an error notice.

I need to change who receives this email. How do I do that?

Please contact SBHVSEN@sallybeauty.com to update our contact database.

My password isn't working. How do I reset it?

Follow the prompts for “Forgot Password” to reset.

I have multiple SKUs on a PO to authorize a return for. Can I just fill out one email?

No, each record must be addressed even if you upload or enter the same information.

What if I don't authorize the return?

Please contact the Planning & Allocation team member in the landing page or that you usually work with to resolve the discrepancy.

Who do I contact if the screen isn't working?

Please contact SBHVSEN@sallybeauty.com for technical assistance.

Can I see all my VSENs at once?

Yes, use this link [Vendor Shipment Error Notification Portal](#) and click on “Vendor VSEN Dashboard.” Login using your email address on your account.

Vendor Scorecard

	Non Error EDI %	855 Compliance %	856 Compliance %	810 Compliance %	860 Compliance %	865 Compliance %	48hr 855 Compliance %	48hr 865 Compliance %
FY'24	99.4%	90.5%	100.0%	96.3%	21.4%	17.4%	71.3%	11.4%
FY'23	98.5%	90.0%	100.0%	97.8%	25.6%	17.5%	66.3%	11.9%

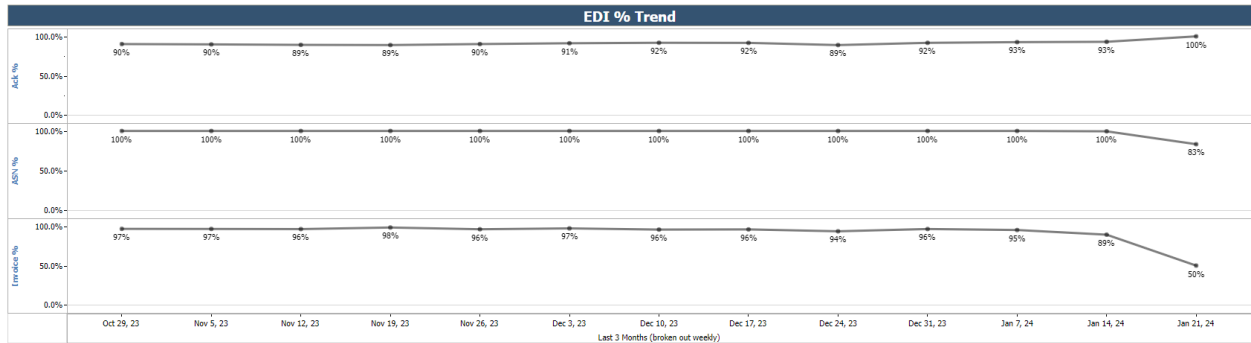

	On Time %	Fill Rate % (Original Qty)	Fill Rate % (Current Qty)	PO Count	Shipment Count	1 ASN per PO %	Original Order Qty	Current Order Qty	Qty Change %
FY'24	93.6%	94.3%	90.8%	13,985	15,309	94.1%	70.17M	72.84M	3.8%
FY'23	90.6%	103.6%	100.0%	35,686	39,970	92.7%	160.50M	166.43M	3.7%

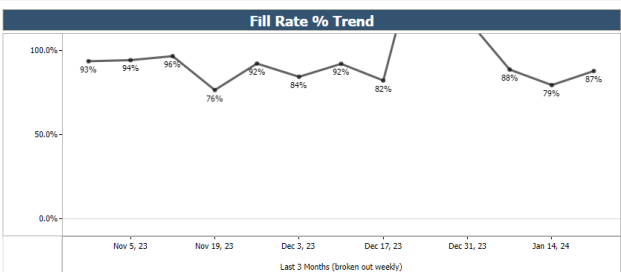
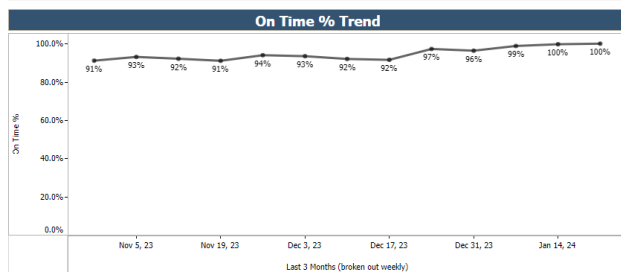

Capture vs Shipment Ratio					
Banner	DC Name	DC Number	Captured Shipment Count	Total Shipment Count	Evaluation %
BSG	Fresno	08997	2,034	1,720	118.26%
	Greenville	06210	217	1,245	17.43%
	Hawaii	09437	212	343	61.81%
	Mississauga	00870	912	340	268.24%
	Spartanburg	06454	1,708	1,779	96.01%
Sally	Columbus	09951	1,310	2,184	59.98%
	Jacksonville	09925	2,156	2,173	99.22%
	Reno	09929	1,310	2,084	62.86%

Total Infraction %				
Task ID	Task Description	Yes	No	N/A
1	Carrier made appointment	96.4%	2.0%	1.5%
2	ASN received for shipment	69.2%	17.2%	13.5%
3	Carrier Arrived +/- 60 min of appointment	94.6%	2.9%	2.6%
4	Pallet label correct location	98.3%	1.5%	0.2%
5	Pallet label contains all required info	97.2%	2.7%	0.1%
6	Pallet is standard size and in good condition	97.8%	2.1%	0.1%
7	Mixed sku pallet identified "Mixed"	65.8%	29.1%	5.1%
8	Packing slip in correct location	91.0%	8.5%	0.6%
9	Packing slip contains all required info	92.2%	6.2%	1.5%
10	Carton labels present	96.0%	4.0%	0.1%
11	Carton labels in correct position	95.8%	4.2%	0.1%
12	Carton labels contain all required info	93.4%	6.5%	0.2%
13	Carton with HAZ material correctly marked	42.6%	1.1%	56.3%
14	SKUs with multiple cartons kept on same pallet (not split across pallets)	85.4%	11.1%	3.5%
15	No visible damage to product detected upon upload	76.8%	23.0%	0.2%
16	No overages, shortages, or incorrect items	50.4%	33.4%	16.2%
Grand Total		84.1%	9.6%	6.3%

PO Number Count	PRO Number Count	Captured Shipment Cou..	Yes %	No %	N/A %	Vendor Perfect Order
8,988	7,935	9,859	84.1%	9.6%	6.3%	1,502 14.9%

*All numerical data is hypothetical and is not based on actual information.

Scorecard Formulas

	Metric	Definition	Calculation	Source(s)
EDI	Non-Error EDI %	Percentage of PO that don't have a single document that errored out in SPS	$[(\text{No. of PO with 0 error documents})/(\text{Total No. of PO})]*100$	SPS
	Acknowledgement %	Percentage of PO that have a PO acknowledgement associated with them	$[(\text{No. of PO with 855})/(\text{Total No. of PO})]*100$	SPS
	ASN %	Percentage of PO that have an ASN associated with them	$[(\text{No. of PO with 856})/(\text{Total No. of PO})]*100$	SPS
	Invoice %	Percentage of PO that have an invoice associated with them	$[(\text{No. of PO with 810})/(\text{Total No. of PO})]*100$	SPS
	PO Change %	Total number of PO changes sent for all PO in question	$[(\text{No. of PO with 860})/(\text{Total No. of PO})]*100$	SPS
	Change Acknowledgement %	Percentage of PO changes that have a change acknowledgement associated with them	$[(\text{No. of 860s with 865})/(\text{Total No. of 860s})]*100$	SPS
	48hr Ack Compliance %	Percentage of 855s received by SPS within 1 business day of SPS transmitting respective PO to vendor	$[(855s \text{ within } 2 \text{ BD})/(\text{Total No. of 855s})]*100$	SPS
	48hr Change Ack Compliance %	Percentage of 865s received by SPS within 1 business day of SPS transmitting respective PO change to vendor	$[(865s \text{ within } 2 \text{ BD})/(\text{Total No. of 865s})]*100$	SPS
	EDI Trend	Rolling 3 months, broken out weekly. Takes the average for all PO within that week.	-	SPS
On Time	On Time %	Currently using Shipment Date as reference from the ASN transmitted via EDI. Percentage of shipments shipped within plus or minus 7 days of Requested Delivery Date on the PO. $([7 \text{ DAYS} - \text{RDD}] < \text{RDD} < [7 \text{ DAYS} + \text{RDD}])$. <i>Future State will use Appointment Date in place of Shipment Date, relative to Delivery Window (Do Not Deliver Before, Do Not Deliver After).</i> See Delivery Windows for more information	$[(\text{No. of Shipments within criteria})/(\text{Total No. of Shipments})]*100$	SPS, EDW
	On Time Trend	Rolling 3 months, broken out weekly. Takes the average for all PO within that week.	-	AS400, EDW
In Full	Fill Rate Original %	Percentage of total PO quantity received in at the DC vs original order quantity on the PO	$[(\text{Qty Received In})/(\text{Original Order Qty})]*100$	EDW, SPS
	Fill Rate Current %	Percentage of total PO quantity received in at the DC vs current order quantity on the PO	$[(\text{Qty Received In})/(\text{Current Order Qty})]*100$	EDW, SPS
	Fill Rate Trend	Rolling 3 months, broken out weekly. Takes the average for all PO within that week.	-	EDW, SPS
Volumes	PO Count	Total number of PO issued, by FY22 and FY23 (YTD)	Total No. of PO	EDW, SPS
	Shipment Count	Total number of 856 received by SBH, by FY22 and FY23 (YTD)	Total No. of 856	SPS
	1 ASN per PO %	Percentage of PO that only have 1 unique ASN attached to them	$[(\text{No. of PO with unique ASN})/(\text{Total No. of PO})]*100$	SPS
	Original Order Qty	Total original order quantity summing up all PO order quantities	Sum of 850 qty	EDW, SPS
	Revised Order Qty	Total revised order quantity summing up all PO change order quantities	Sum of 860 qty	SPS
	Qty Change %	Percentage change from original order quantity to revised order quantity (Ideal Case 0%)	$(\text{Revised Order Qty} - \text{Original Order Qty})/(\text{Original Order Qty})$	EDW, SPS

3WM	Invoice Amount	Total amount invoiced by vendor, for all PO	Sum of 810 amounts	Oracle EBS
	Invoice Amount After Discount	Total amount invoiced by vendor factoring in the discount terms provided by vendor, for all PO	Sum (810 amount - Proposed Discount Amount)	Oracle EBS
	Amount Paid	Total amount paid out to the vendor, for all PO	Sum of paid amounts	Oracle EBS
	\$ Change %	Percentage change from invoice amount after discount to amount paid (Ideal Case 0%)	$(\text{Amount Paid} - \text{Invoice Amount AD}) / (\text{Invoice Amount AD})$	Oracle EBS
	Available to Pay %	Percentage of PO whose invoices are not on hold (system hold or manual hold) and can be paid	$[(\text{No. of PO not on hold}) / (\text{Total No. of PO})] * 100$	Oracle EBS
	On-Time Payments	Percentage of PO whose invoices whose payment date is before the due date set by vendor	$[(\text{No. of PO paid on time}) / (\text{Total No. of PO})] * 100$	Oracle EBS
	No Touch, On Time	Percentage of PO whose invoices were paid out before the due date and passed through the 3WM without any manual intervention	$[(\text{No. of PO paid on time \& without intervention}) / (\text{Total No. of PO})] * 100$	Oracle EBS
	Manual vs No Touch	Breakout percentage of PO whose invoices passed through the 3WM process without intervention (No Touch) vs when 3WM process failed and manual intervention was needed to pass the 3WM process (Manual)	$(\% \text{ Manual}) + (\% \text{ No Touch}) = 100\%$ $\% \text{ Manual} = [(\text{No. of PO that needed intervention}) / (\text{Total No. of PO})] * 100$ $\% \text{ No Touch} = [(\text{No. of PO with no intervention}) / (\text{Total No. of PO})] * 100$	Oracle EBS

Warehouse Load Evaluation Metrics

Metric	Calculation
ASN received for shipment	Yes % = [(Sum of Yes)/(Total Shipments Evaluated)]*100
Carrier made appointment	
Carrier Arrived +/- 60 min of appointment	
Pallet label correct location	
Pallet label contains all required info	
Pallet is standard size and in good condition	
Mixed SKU pallet identified "Mixed"	
Packing slip in correct location	
Packing slip contains all required info	
Carton labels present	
Carton labels in correct position	
Carton labels contain all required info	
Carton with hazardous material correctly marked	
SKUs with multiple cartons kept on same pallet (not split across pallets)	
No visible damage to product detected upon upload	
No overages, shortages, or incorrect items	

At a Glance

Contact Information and Important Links

Internal SBH	Contact
Vendor Performance Team	vendorperformance@sallybeauty.com
EDI Support	sbh-edi@sallybeauty.com
Transportation	sbhtransportation@sallybeauty.com
Accounts Payable	AccountsPayableInquiries@SallyBeauty.com ¹¹

SBH Partners	Contact
Transportation	TPS Logistics (248) 731-4725 SBA@tpslogistics.com
SPS Commerce	866-245-8100 https://www.spscommerce.com/

For Vendors: How to update enterprise information

	SBH Vendor Performance Contact Database
---	---

Distribution Center Listing

Warehouse and Location ID	Address and Hours	Appointment Email
Beauty Systems Group		
Calgary 7010	Beauty Systems Group Canada INC (BSG) Monarch WHSE 5381 72 Ave SE Suite 54 Calgary, AB, T2C 4X6	RecvAppt-BSGCalgary@cosmoprofbeauty.com
Mississauga 7087	Beauty Systems Group Canada INC (BSG) Beauticians' Supply 395A Pendant Dr Mississauga, ON L5T 2W9	RecvAppt-BSGMississauga@cosmoprofbeauty.com
Fresno 8997	Arcadia Beauty Labs LLC 480 E North Ave Suite 104 Fresno, CA 93706	RecvAppt-BSGFresno@Sallybeauty.com
Greenville 6210	Arcadia Beauty Labs LLC 5805 Jaysville - St John Rd Greenville, OH 45331	RecvAppt-BSGGreenville@sallybeauty.com
Hawaii 9437	Beauty Systems Group LLC 99-1434 Koaha Place Aiea, HI 96701	RecvAppt-BSGHawaii@Sallybeauty.com
NTX Alliance 95009	Arcadia Beauty Labs LLC 15453 Wolff Crossing Justin, TX 76247-7734	RecvAppt-AllianceDC@Sallybeauty.com
Puerto Rico 5290	Sally Beauty de Puerto Rico, Inc Central Plaza Ind Park Catano, PR 00962	eacosta@islandwide.com
Spartanburg 6454	Arcadia Beauty Labs LLC 310 John Martin Rd Spartanburg, SC 29303	RecvAppt-BSGSpartanburg@Sallybeauty.com
Sally Beauty Supply		
Columbus 9951	Arcadia Beauty Labs LLC 4309 Janitrol Road Columbus, OH 43228	RecvAppt-SallyColumbus@Sallybeauty.com
Jacksonville 9925	Arcadia Beauty Labs LLC 1550 Vantage Way Jacksonville, FL 32218	RecvAppt-SallyJacksonville@Sallybeauty.com
Reno 9929	Arcadia Beauty Labs LLC 9975 Moya Blvd Reno, NV 89506	RecvAppt-SallyReno@Sallybeauty.com
Happy Beauty Co.		
NTX Alliance 95025	Arcadia Beauty Labs LLC 15453 Wolff Crossing Justin, TX 76247-7734	RecvAppt-AllianceDC@sallybeauty.com

Requirements Checklist Table

EDI



- 100% compliant exchanging all six (6) transaction sets
- 855 transmitted within 48 hours of PO 850
- 865 transmitted within 48 hours of PO Acknowledgement 860

Pallet Integrity and Labels

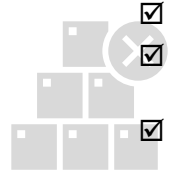

- Pallet label affixed to all pallets in correct location
- Pallet label contains all required info
- Mixed SKU pallet clearly marked "Mixed SKU"
- Keep cases of same SKU on same pallet
- Pallet in good and useable condition
- Pallet standard 40" x 48" size, not packed higher than 55"
- Cartons secured with no overhang

Packing Slip



- Packing slip affixed to all shipments in correct location
- Packing slip contains all required info

Carton and Product Markings



- Hazardous materials clearly marked with correct symbols
- Perishable product contains expiration date > 12 months from receipt date
- Scannable UPC on item packaging (floor ready)
- One lot number per same SKU

Carton Integrity and Labels

- Carton label affixed to all pallets in correct location
- Carton label contains all required info
- Scannable GS1-128 barcode
- Carton has structural integrity to move through supply chain
- Within dimension range: Min 9" x 7" x 3" / 18 x 23 x 8 cm, Max 25" x 22" x 23" / 64 x 56 x 58 cm ¹²
- Within weight range: Min 2lbs / 1kg, Max 35lbs / 15kg ¹³
- Cartons with loose goods have inner voids filled
- Acceptable packing materials used (sustainable preferred)

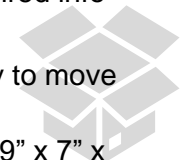

Delivery and Appointments

- All LTL and FTL have appointment made with warehouse
- ASN present at time of Appointment scheduling
- Same SKU not split amongst pallets or trucks unless qty requires



Accuracy

- Ship 100% complete to 850 or 860 where applicable
- No substitutions or overages
- Carrier arrives +/- 60 min of appointment
- Delivered within Delivery Window



2024 Changes ¹⁴

Immediate or Cancel Policy

Starting from 2024, SBH will implement an "Immediate or Cancel" (IOC) policy for purchase orders. **The purpose of IOC is to identify which lines on a Purchase Order can be executed immediately and completely.** Any non-executed lines or quantities, whether due to out of stock, backorder, discontinuation, or any other reasons, should be cancelled by the Vendor in the PO Acknowledgement (855).

To ensure the successful execution of IOC, SBH is relying on the Vendor to carefully review the **PO Type** (BEG 02) and **Do Not Deliver After** (DTM 01) date. If a line cannot be filled in the requested quantity by the Do Not Deliver After date, the Vendor must indicate the quantity that it can fill or cancel the line if it cannot be filled at all. SBH will respond with a PO Change (860) acknowledging the changed or cancelled amount.

Vendors are expected to ship orders complete and in full as confirmed in the PO Acknowledgement. Any lines or quantities that are not shipped for purchase orders under the IOC policy will be cancelled by SBH when receiving and reconciling the Vendor's Advance Ship Notice (856).

PO Type Code	PO Type Description	IOC Expectations
DR	Direct Ship	Vendor should cancel any lines or reduce quantities that cannot be immediately fulfilled
DS	Drop Ship	
SA	Stand Alone	
NS	Launch	<i>Backorders (IB) and Date Reschedule (DR) Permitted on 855; Quantity and Date Fields Required when used</i>
PR	Promo	
SS	Supplies	Vendor should cancel any lines or reduce quantities that cannot be immediately fulfilled
SA	Import (same as Stand Alone)	

Delivery Windows

In 2024, SBH will be introducing a 9-day Delivery Window that will apply to all Purchase Orders regardless of a Vendor's location and transit time to SBH facilities. The window will begin in the final 2 days of a Vendor's specified transit time and end 7 days after an expected arrival. Here are some examples of various transactions for reference:

Order

PURCHASE ORDER #: 980123456
 DEPOSITOR ORDER #:
 CUSTOMER ORDER #:
 RELEASE #:
 PURCHASE ORDER TYPE: Stand Alone [SA]
 TRANSACTION CODE: Original [00]
 BUYERS CURRENCY: USD
 SELLERS CURRENCY:

SHIP TO [ST]:
 Location ID: 95009
 NTXB5G DC
 Arcadia Beauty Labs LLC
 15453 Wolff Crossing

BILL TO PARTY [BT]:
 Arcadia Beauty Labs LLC
 ATTN: Accounts Payable
 PO Box 90219
 Denton, TX 76202 USA

PURCHASE ORDER DATE:	2023-10-01
DO NOT DELIVER BEFORE [064]:	2023-10-16
DO NOT DELIVER AFTER [063]:	2023-10-24
VENDOR: 12345	DEPARTMENT:
ACCOUNT #:	

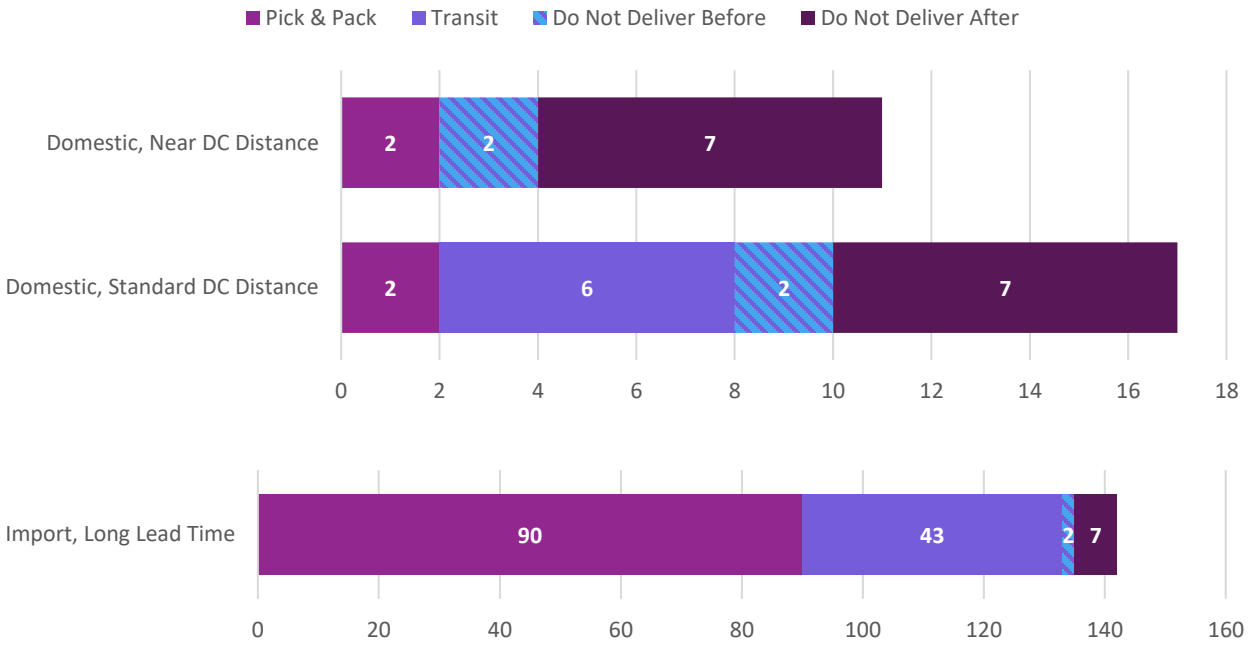

“On-Time” will be calculated and evaluated if the carrier appointment date is within the 9-day period.

To guarantee that Purchase Orders are fulfilled within feasible timeframes and each Vendor attains its on-time target, SBH has developed a link for each vendor to update their Pick & Pack and Transit time for each SBH Distribution Center. This will help ensure that Purchase Orders are properly scheduled and Vendors are able to meet their delivery deadlines. Please click [HERE](#) or use the QR code in [Contact Information and Important Links](#) to update transaction time.

EDI Mapping Changes

This is to inform you about recent EDI mapping changes that were made to support changes in SBH business processes. We have updated each our transaction sets to reflect these changes and encourage you to review them carefully.

The mapping changes have been included in each of the mapping documents for your convenience. Please review the updated documents and make any necessary updates to your processes accordingly.

SBH EDI mapping documents are found here: <https://community.spscommerce.com/sally-beauty-fulfillment/>

Please notify the appropriate teams in your organization of these changes, including third party EDI vendors you may use.

850 Original Purchase Order

BEG – Beginning Segment for Purchase Order

BEG02 – 4 additional possible Purchase Order Type Codes will be included

PO Type Code	PO Type Description	Status
DR	Direct Ship	Existing
DS	Drop Ship	Existing
SA	Stand Alone	Existing
NS	Launch	New
PR	Promo	New
SS	Supplies	New
SA	Import (same as Stand Alone)	Existing

DTM – Date/Time Reference

DTM01 – Date code '001' will be removed from the mapping. Effective with this mapping change, POs will no longer be sent with a single 'Delivery Requested' date (code '002'). POs will be transmitted with a delivery window using codes '064' Do Not Deliver Before & '063' Do Not Deliver After.

PO1 – Baseline Item Data

PO104 – SBH will continue to transmit all items pricing data using 2-decimal places. Please note that all return documents that contain item price data will be restricted to 2-decimal places.

860 Purchase Order Change

BEG – Beginning Segment for Purchase Order

BEG02 – 4 additional possible Purchase Order Type Codes will be included

PO Type Code	PO Type Description	Status
DR	Direct Ship	Existing
DS	Drop Ship	Existing
SA	Stand Alone	Existing
NS	Launch	New
PR	Promo	New
SS	Supplies	New
SA	Import	Existing

DTM – Date/Time Reference

DTM01 – Date code '001' will be removed from the mapping. Effective with this mapping change, POs will no longer be sent with a single 'Delivery Requested' date (code '002'). POs will be transmitted with a delivery window using codes '064' Do Not Deliver Before & '063' Do Not Deliver After.

PO1 – Baseline Item Data

PO104 – SBH will continue to transmit all items pricing data using 2-decimal places. Please note that all return documents that contain item price data will be restricted to 2-decimal places.

POC – Line Item Change

POC02 – Additional item level change codes will be included while one code will be removed for greater clarity in describing the changes made.

Change Type Code	Change Type Description	Status
AI	Add Additional Item(s)	Existing
CA	Changes to Line Items	Removed
DI	Delete Item(s)	Existing
RZ	Replace All Values	Existing
PC	Price Change	New
PQ	Price & Quantity Change	New
QD	Quantity Decrease	New
QI	Quantity Increase	New

855 Purchase Order Acknowledgment

DTM – Date/Time Reference

Date code '002' has been removed and replaced with codes '064' Do Not Deliver Before and '063' Do Not Deliver After.

We are adding validation logic to confirm that header level acknowledgment codes are aligned with item level acknowledgment codes when item details are sent. We expect that if a PO is accepted or rejected in full, with item details included, that all item level codes would also show as accepted or rejected to match the header level code.

If BAK02 = 'AD' (Acknowledge – With Detail, No change) then ALL item level details MUST return code 'IA' in ACK01.

If BAK02 = 'RD' (Acknowledge – With Detail, No change) then ALL item level details MUST return code 'IR' in ACK01.

ACK – Line Item Acknowledgment

ACK04 – We have removed date code '068' and replaced it with '063' Do Not Deliver After

865 PO Change Acknowledgment

No changes have been made.

856 Advance Ship Notice (ASN)

TD5 – Carrier Details

TD505 has been changed to be a mandatory data element.

810 Invoice

TXI – Tax Information

TXI01 – Tax code 'ST' has been added for use when state/local sales taxes are required on the invoice.

TXI09 has been added to communicate a TAX ID, and is required if TXI01 contains either codes 'BE' or 'GS' for Canadian taxes.

EDI Timeline 2023-2024

NOVEMBER		
TASK/ACTIVITY	DUE DATE	RESPONSIBLE
Launch EDI Remapping and Recertification	11/07/23	SBH
Outreach: EDI Commitment Date	11/07/23 – 12/08/23	SPS Commerce
Attend SPS On-demand Webcast	Beginning 11/07/23 through testing	Vendors
DECEMBER		
TASK/ACTIVITY	DUE DATE	RESPONSIBLE
Commitment Due Date: Suppliers return all testing commitments and update contacts to SPS Commerce	12/08/23	Vendors
Deadline to submit updated contact information and shipping documents to SBH	12/29/23	Vendors
Deadline to submit transit times to SBH	12/29/23	Vendors
JANUARY		
TASK/ACTIVITY	DUE DATE	RESPONSIBLE
Begin EDI testing configurations with SPS Commerce	01/08/24	Vendors and SPS
Outreach: Immediate or Cancel Policy	01/08/24 – 03/01/24	SBH
FEBRUARY		
TASK/ACTIVITY	DUE DATE	RESPONSIBLE
1 st Non-Compliance Warning	02/02/24	SBH
2 nd Non-Compliance Warning and Production Ready Goal	02/16/24	SBH
MARCH		
TASK/ACTIVITY	DUE DATE	RESPONSIBLE
3 rd and Final Non-Compliance Warning (cessation of future purchase orders)	03/01/24	SBH
EDI Go-Live	03/04/24	SBH
Immediate or Cancel effective (including delivery windows)	03/04/24	SBH

Integration of Vendor ASN to SBH Warehouse Management Systems

Starting in 2024, SBH will migrate its technology from receiving based on Purchase Orders (850) to receiving based on a Vendor's Advance Ship Notice (856). This means that inbound transaction sets will be incorporated into our warehouse management systems, allowing us to better track incoming shipments and improve the speed and accuracy of our receiving process. In addition, we will be [associating each carton label to the ASN](#). For our Vendor partners, the benefits are:

- Reduce order to payment cycles
- Get products on store shelves faster
- More easily track shipments en route
- Track any missing cartons and make claims accordingly
- Improve retailer relationships by reducing stock outs, errors and missed deliveries

Communication will be shared as the technology solutions are available. SBH will be monitoring compliance with carton barcode labels to ensure the use of the ASN is as impactful as possible. Please visit [SPS Commerce](#) to learn more about the benefits and common issues to watch out for in your EDI mapping.

Common issues regarding EDI 856

Barcode labels:

Issues with barcode labels, such as discrepancies between the barcode and the ASN, can occur. This often results in requiring the receiver to manually sort packages, leading to increased labor costs and potential chargebacks or penalties for suppliers.

Completeness and accuracy:

If ASN data isn't accurate or complete, there will be delays, lost productivity and customer service shortfalls. Validating the completeness and accuracy of the ASN data is important to avoid confusion and subsequent penalties and fines.

Timeliness:

Trading partners typically require an ASN to arrive prior to the shipment. Understanding each trading partner's requirements for ASN delivery will help prevent chargebacks.

Canada PO Migration

SBH has deployed several modern, best-in-class supply chain software solutions in recent years. Two of our most important migrations have been the transition of our inventory management software onto the BlueYonder (JDA) suite of applications and transitioning our procure-to-pay lifecycle to a fully structured, machine-processable format of documentation via Electronic Data Interchange (EDI). The benefits of exchanging our documents in BlueYonder manifest in time savings and associated financial savings accrued from:

- Reduced document processing and transmittal costs;
- Elimination of keying of redundant information; and
- Reduction of manual reconciliation of information.

Please document the following identification numbers that you will see on transactions effective upon program announcement:

- Vendor Number: 5 digits instead of 3
- Currency: USD or CAD ¹⁵
- Calgary Warehouse Location #: 7010
- Mississauga Warehouse Location #: 7087

In addition, please be aware that the SBH internal SKU will be different when purchase orders are issued from BlueYonder. Our internal SKUs are now 7 digits long, beginning with a 1 or a 2 instead of 6 digits. The UPC/GTIN-12 and your organization's Part Number will still transmit in the transaction sets. Should you require a list of your organization's assortment with our SKU numbers, Legacy and BlueYonder, please notify vendorperformance@sallybeauty.com with the subject line "SKU Conversion Request".

Lastly, please take a moment to re-familiarize yourself with our EDI Value-Add Network partner, [SPS Commerce](#). Please ensure all logins and users on your end are authenticated by December 8, 2023. To seek additional help and learn about which EDI segments these fields will be present in, please contact sbh-edi@sallybeauty.com.

Change Control

*The list of items below represents changes to the Vendor Performance Requirements Manual since the prior published version on **July 6, 2023**.*

- 1 Clarification on time limits to complete testing, based on a Vendor's technology solution for accessing and exchanging EDI transaction sets
- 2 Confirmation to use EDI only to request changes to Purchase Orders
- 3 Vendor Performance does not authorize backorder status
- 4 Clarification on how to identify shortages discovered during the Vendor pick process
- 5 Additional context on the technology enhancements SBH is making to rely on the Vendor ASN as a receiving source record
- 6 Clarification on expectations, recognizing that carriers may reorganize pallets during transit that Vendor cannot control
- 7 Clarification on expectations, recognizing that carriers may reorganize pallets during transit that Vendor cannot control
- 8 Clarification on the requirement and association to the Advance Ship Notice (856)
- 9 This section has been updated to include both Imperial and Metric dimensions.
- 10 Updated with new carrier (formerly YRC and Holland)
- 11 Updated email address for SBH Accounts Payable
- 12 Includes both Imperial and Metric length
- 13 Includes both Imperial and Metric mass
- 14 Provided for easy reference and socialization within Vendor organization
- 15 Currency selection is based on remittance information submitted to SBH Accounts Payable. For questions, please contact AccountsPayableInquiries@SallyBeauty.com.